

RI-F220 Series

Single and Three Phase Multifunction Energy Meter



- DIN 72 panel mounted
- -/1A or -/5A current transformer input
- Single phase or three phase network compatible
- Programmable voltage and current transformer ratio
- True RMS measurement
- High definition white backlit LCD display
- Simple programming and operation
- Pulse output and Modbus communication
- Auto and manual page scrolling

Product Description

The RI-F220 series are a range of DIN 72 panel mounted multifunction energy meters. Suitable for monitoring energy consumption and many other electrical parameters in industrial and commercial applications.

These meters may be used in single or three phase balanced or unbalanced load systems.

A high efficiency white backlit LCD display provides a clear indication of the measured value in all light conditions.

Quick select push-buttons on the front of the meter allow the user fast access to the display page required.

The meter is available in two versions:-

- With single pulse output.
- With single pulse output and RS485 Modbus communication.

The unit is housed in a compact DIN 72 case suitable for panel mounting.

Displayed Parameters

Voltage – L-L, L-N and average
Current – Phase, total and Max. demand
Power Factor – per phase and average
Total Harmonic Distortion – Current and Voltage
Neutral current (calculated)
Frequency
Hours Run – Hours & minutes
Power – Active, Reactive and Apparent (per phase and total)
Power Min./Max. demand – Active, reactive and apparent.
Energy – Active, reactive and apparent (per phase and total)
Import and export energy – Active, Reactive and Apparent (per phase and total)

Display

Display Type	High definition white backlit LCD
Digit height	8mm (displayed parameter) 5mm (lowest 8 digits)
Page scrolling	Manual by front key / or auto scroll mode
Displayed parameters and accuracies	Voltage 0.5% of full scale Current 0.5% of full scale Frequency 0.1% of full scale (L - N >20V) Power factor 1% of unity Active power 1% Reactive power 1% Apparent power 1% Active Energy Class 1 (IEC/EN62053-21) Reactive Energy Class 2 (IEC/EN62053-23) Total Harmonic Distortion (THD - up to 31st) 3% 99999999
Energy maximum display	0.01K, 0.1K, 1K, 0.01M, 0.1M, 1M (depending on CT ratio & VT ratio)
Resolution	

Programming

Parameters that can be changed using programming menu	CT Primary current CT Secondary current VT primary voltage VT secondary voltage Communication address Communication speed (Baud) Communication Parity Communication number of stop bits Back-light time-out period Demand period (for integration) Pulse output (kWh) Pulse duration Reset to Factory Default Reset Energy and Maximum Demand Reset Active Energy Reset Reactive Energy Reset Apparent Energy Reset Maximum Current Reset Maximum Active Power Reset Minimum Active Power Reset Maximum Reactive Power Reset Minimum Reactive Power Reset Maximum Apparent Power
Programming access	Password protected (user selectable)
Memory retention	Non volatile memory

Input

Connection	Single phase (selectable L1, L2 or L3 CT connection), Three phase three wire, Three phase four wire
Input voltage range	11...300V (L - N), 19...519V (L - L)
Voltage Rated Burden	0.2VA
Nominal current input	1A, 5A
Max current (Imax)	1.2A, 6A (1.2 x Nominal)
Current Rated Burden	0.5VA
Starting current	0.2% of nominal
Short time over-current	30 x Imax to IEC/EN62053-21 + 23
Impulse voltage withstand	6kV 1.2/50µS 0.5J
AC voltage withstand	4kV 50Hz for 1 min.
CT primary current	1A, 5A...10000A
VT primary voltage	100...500KV
Frequency	45...65Hz

Auxiliary Supply

Voltage range	100...240V (±15%)
Operating frequency	50/60Hz ±5%
Power consumption	<8VA

Outputs

Energy pulses	
Number of pulse outputs	1
Pulse output function	kWh
Pulse output type	Semiconductor (does not support volt-free operation)
Pulse output Max. current	100mA
Pulse output voltage range	5...27VDC
Pulse duration	100ms...2s
Pulse resolution	0.01K, 0.1K, 1K, 0.01M, 0.1M, 1M (depending on CT ratio & VT ratio)
Communication	
Communication type	RS485
Communication protocol	Modbus
Address	1...255
Number of bits	8bits
Parity	None, odd, even
Baud rate	300, 600, 1200, 2400, 4800, 9600, 19200
Required response time to request	≤100ms
Number of meters connected on the bus	32 (up to 255 with RS485 repeater)
Max distance from Master device	500M

Insulation

Installation category	III
Pollution degree	2
Insulation voltage rating	300V (L - N)

Environmental Conditions

Reference temperature	23°C ±2°C
Specified temperature operating range	-10°C...+55°C
Storage temperature	-20 ° C...+70 ° C
Relative humidity	0...85%, non-condensing

M e c h a n i c a l

Housing	
Housing	D I N 72
M ounting	Panel mounted (Max. panel thickness 6mm)
Tamper sealing	Meter housing (by means of a tamper evident seal)
Housing material	Self-extinguishing polycarbonate (UL94 V-0)
Protection degree (IEC/EN60529)	IP20 (terminals), IP54 (front of housing)
Weight	< 320g
Termination	
Current input terminal type	Screw clamp type
Max. wire size	2.5mm ²
Voltage input terminal type	Screw clamp type
Max. wire size	2.5mm ²
Output terminal type	Screw clamp type
Max. wire size	2.5mm ²

Conformity

Electromagnetic compatibility	IEC/EN61326-1, IEC/EN55011 Class A, IEC/EN61000-4-2, -3, -4, -5, -6, -8, -11
Accuracy and functionality	IEC/EN62053-21, IEC/EN62053-23
S a f e t y	I E C / E N 61010

Wiring Diagrams

Note: # All fuse types : 0.5A class CC UL type
0.5A fast acting 600V

3 Phase 4 Wire - 3 CTs

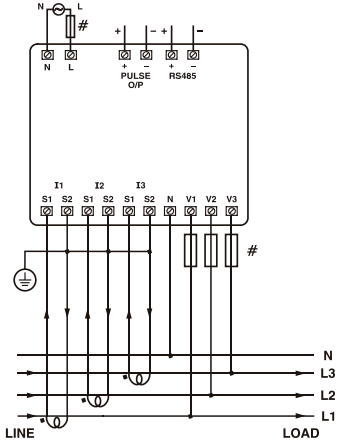

2 Phase 3 Wire - 2 CTs

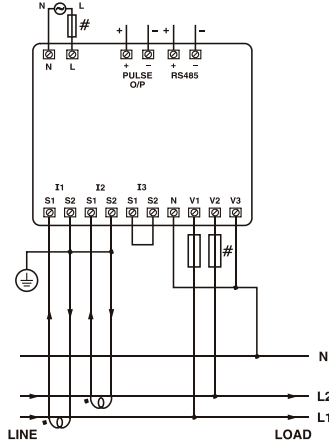

3 Phase 3 Wire - 2 CTs

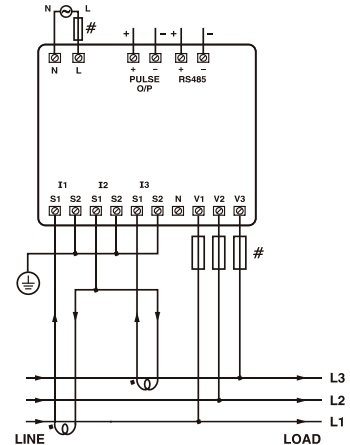

3 Phase 4 Wire - 3 CTs and 3 PTs

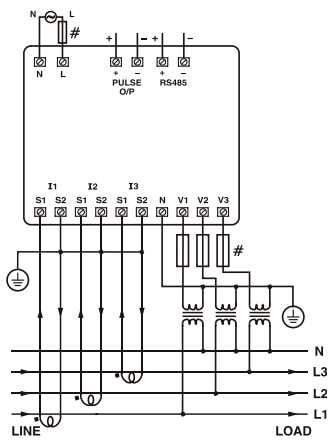

2 Phase 3 Wire - 2 CTs and 2 PTs

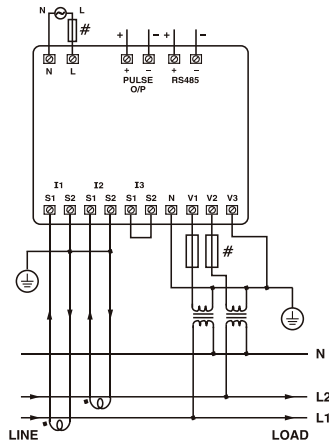

3 Phase 3 Wire - 2 CTs and 2 PTs

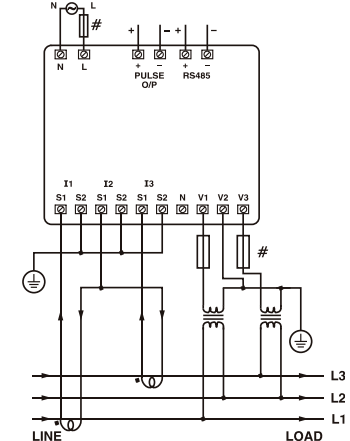

Single Phase 2 Wire - 1 CTs

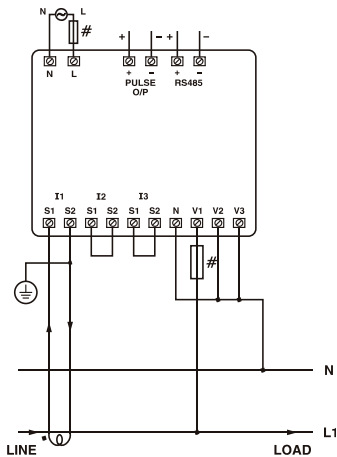

Accessories

The RI-F220 comes supplied with a transparent connections cover with holes for anti-tamper tags and slide-in ratcheted fixing clips for easy and precise fitting of the meter.



Dimensions

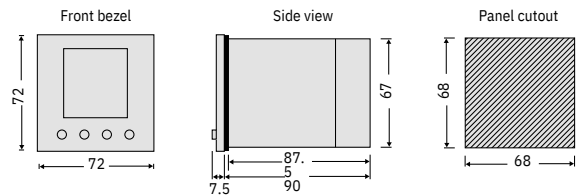

Model Selection Table

Communications	Model
Pulse output	RI-F220-G-P
Modbus and pulse output	RI-F220-G-C